

ECE 761: Homework #13: Jacobians and Cartesian Control

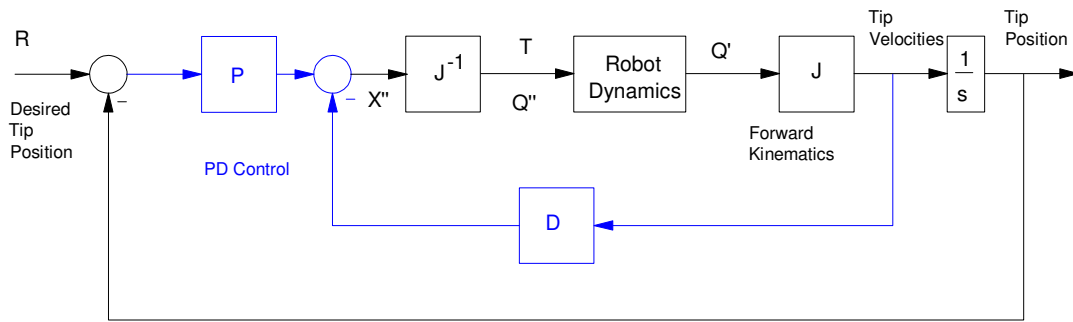

For a 2-link arm, assume the tip position is

$$P2 = (1.1, 0.5)$$

- 1) Determine the joint angles at this point
- 2) Determine the Jacobian at this point
- 3) Determine the joint velocities if the tip velocity is moving towards point 3:

$$\begin{bmatrix} \dot{x}_2 \\ \dot{y}_2 \end{bmatrix} = \begin{bmatrix} -0.5 \\ 0 \end{bmatrix} \text{ m/s}$$

- 4) Determine the tip velocity if the joint velocity is

$$\begin{bmatrix} \dot{\theta}_1 \\ \dot{\theta}_2 \end{bmatrix} = \begin{bmatrix} 0.1 \\ 0.2 \end{bmatrix} \text{ rad/sec}$$

Write a program (modify RR_XY_Control.txt) to trace out a square with corners at

- P0 = (0.1, -0.5) t = 0 seconds
- P1 = (1.1, -0.5) t = 4 seconds
- P2 = (1.1, +0.5) t = 8 seconds
- P3 = (0.1, 0.5) t = 12 seconds
- P4 = P0 = (0.1, -0.5) t = 16 seconds

- 5) Using cosine interpolation between points, and
- 6) Using no interpolation (step change: a = 1)