

# ECE 321 - Quiz #4 - Name \_\_\_\_\_

## BJT Amplifiers & 2-Port Models

1) BJT Amplifier: DC Analysis. Determine the Thevenin equivalent of R1 and R2 as well as the Q-point. Assume ideal silicon transistors:

- $V_{be} = 0.7V$
- $\beta = 30$
- $R_e = 900 + 100 * (\text{your birth month}) + (\text{your birth day})$

$R_e$ 900 + 100*mo + day	$V_b$	$R_b$	$V_{ce}$	$I_c$
<b>1414</b>	<b>3.00V</b>	<b>75k</b>	<b>9.41V</b>	<b>580.6uA</b>

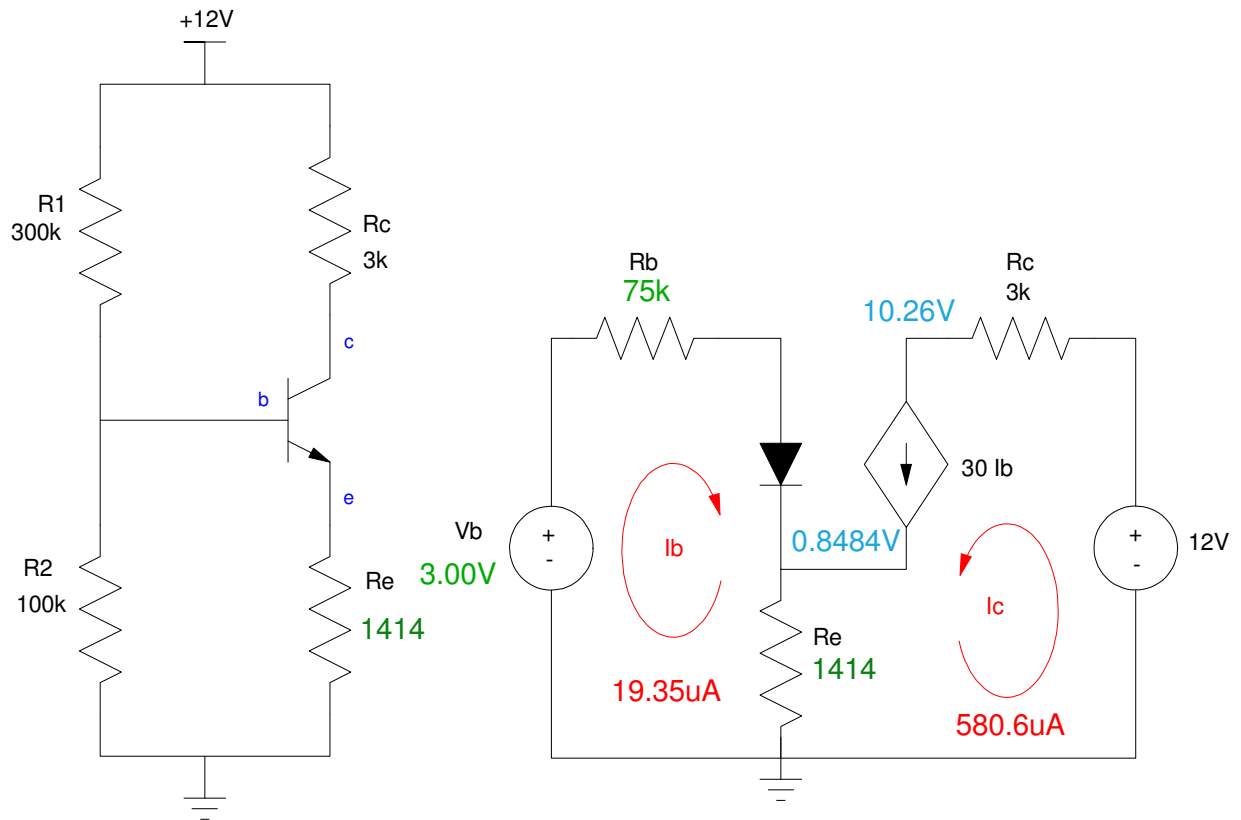

2) BJT Amplifier: DC Design. Determine R1 and R2 so that

- The Q point is  $V_{ce} = 6.00V$  and
- The Q point is stabilized for variations in  $\beta$

Assume

- Ideal silicon transistors ( $V_{be} = 0.7V$ ,  $\beta = 30$ )
- $R_e = 900 + 100 * (\text{birth month}) + (\text{birth day})$

$R_e$ 900 + 100*mo + day	R1	R2	$V_b$	Rb
<b>1414</b>	<b>24.43k</b>	<b>4783</b>	<b>1.965V</b>	<b>4k</b>

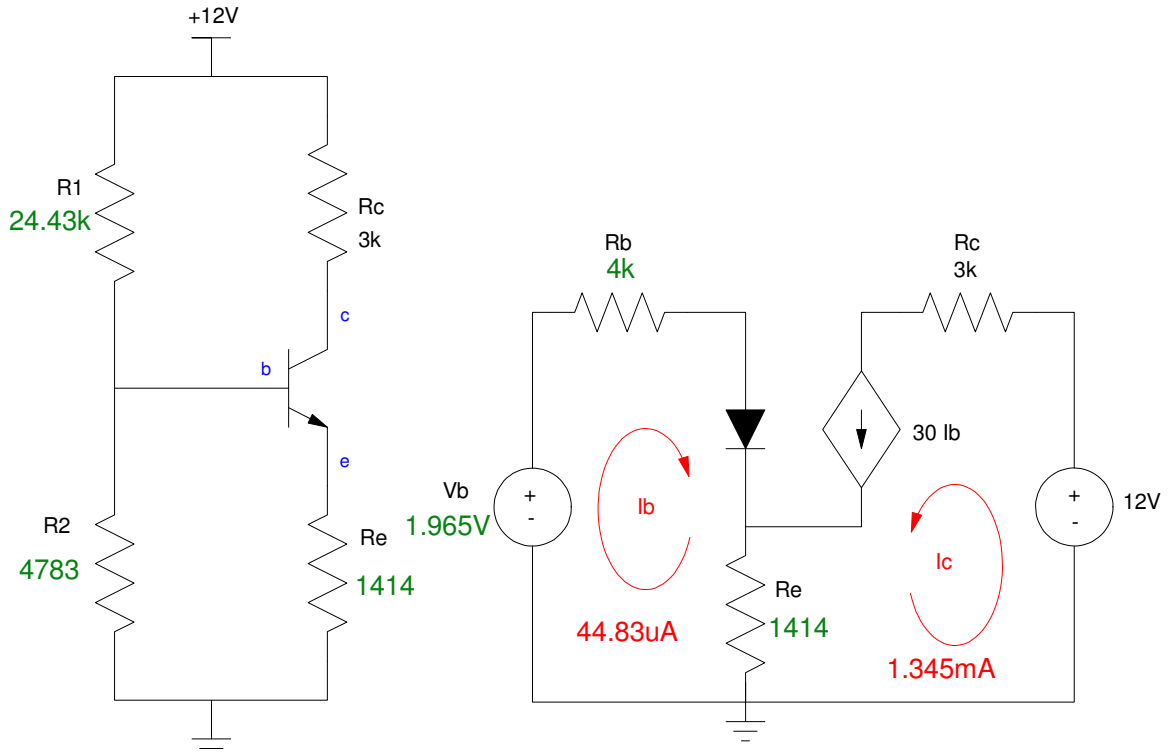

To stabilize the Q-point

$$(1 + \beta)R_e \gg R_b$$

$$43.83k\Omega \gg R_b$$

Let  $R_b = 4k$

For  $V_{ce} = 6V$

$$I_c = \left( \frac{12V - 6V}{3000 + 1414 \left( \frac{31}{30} \right)} \right) = 1.345mA$$

$$I_b = \frac{I_c}{30} = 44.83\mu A$$

$$V_b = R_b I_b + 0.7 + R_e (I_b + I_c) = 1.965V$$

$$R_1 = \left( \frac{12V}{1.965V} \right) R_b = 24.43k\Omega$$

3) BJT: AC Analysis: Draw the small signal model for the following BJT amplifier. Assume

- $r_f = 2000\Omega$
- $\beta = 30$

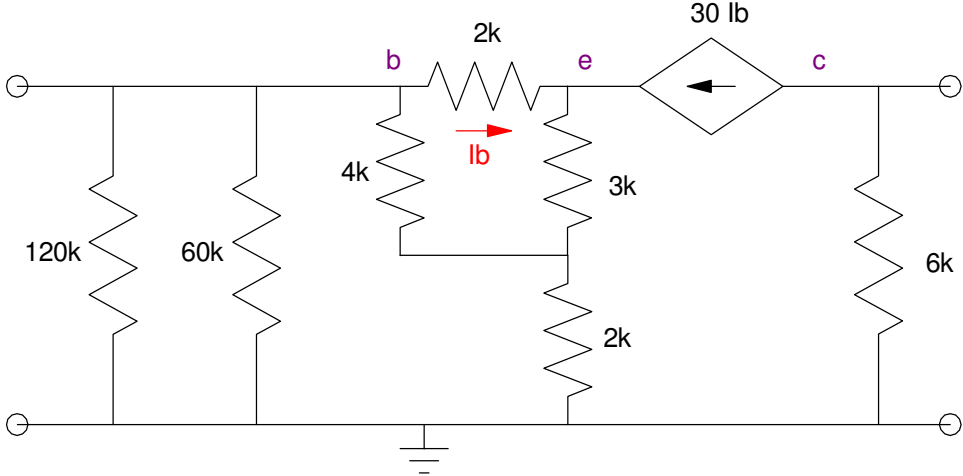
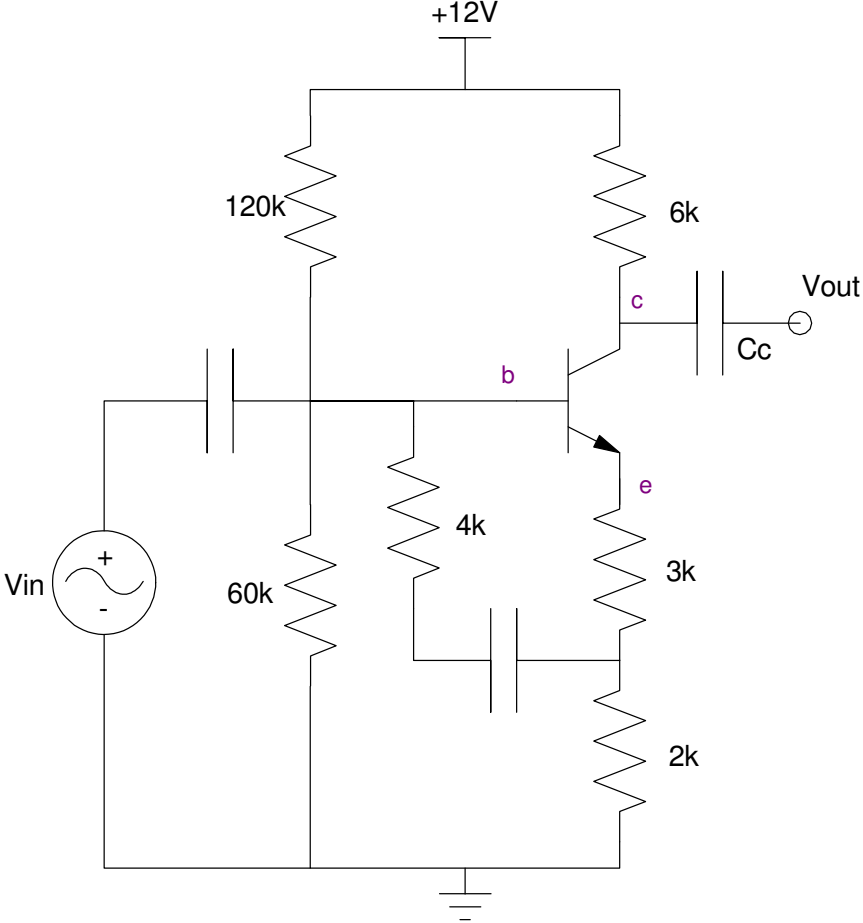

4) 2-Port Models. Determine the 2-port model for the following circuit:

R 900 + 100*mo + day	R <sub>in</sub>	A <sub>in</sub>	R <sub>out</sub>	A <sub>o</sub>
<b>1414</b>	<b>1828</b>	<b>0</b>	<b>2961</b>	<b>-6.53</b>

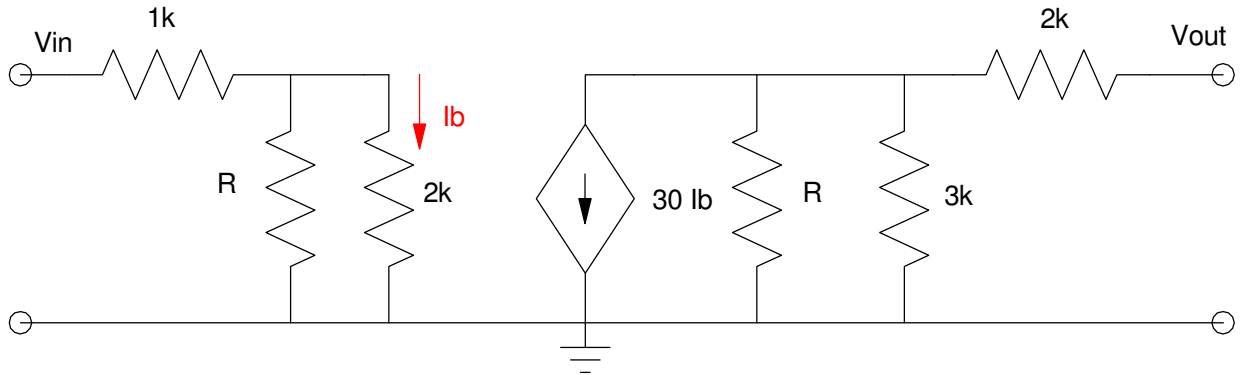

$$R_{in} = 1k + 1414 \parallel 2000 = 1828$$

$$A_{in} = 0$$

$$R_{out} = 2k + 3k \parallel 1414 = 2961$$

A<sub>o</sub>: Set V<sub>in</sub> = 1V

$$V_b = \left( \frac{828.4}{828.4 + 1k} \right) 1V = 0.4531V$$

$$I_b = \left( \frac{0.4531V}{2k} \right) = 226.5\mu A$$

$$30I_b = 6.796mA$$

$$V_{out} = -6.796mA \cdot (1414 \parallel 3000)$$

$$V_{out} = -6.531V$$

$$A_o = -6.531$$

5) 2-Port Models. Determine the 2-port model for the following circuit:

R 900 + 100*mo + day	R <sub>in</sub>	A <sub>in</sub>	R <sub>out</sub>	A <sub>o</sub>
<b>1414</b>	<b>22.35k</b>	<b>0</b>	<b>1714</b>	<b>-1.273</b>

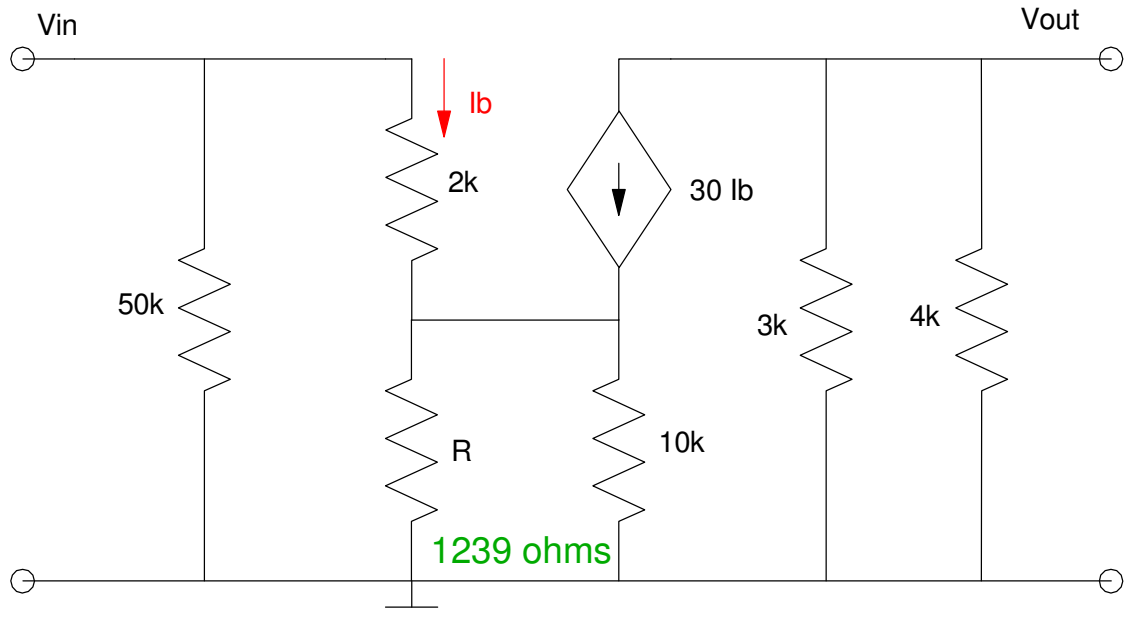

$$R_{in} = 50k \parallel (2k + 31(1239))$$

$$R_{in} = 22.35k\Omega$$

$$A_i = 0$$

$$R_{out} = 3k \parallel 4k = 1714 \text{ Ohms}$$

A<sub>o</sub>: Apply 1V to Vin

$$I_b = \left( \frac{1V}{2k + 31 \cdot 1239} \right) = 24.75\mu A$$

$$I_c = 30I_b = 742.6\mu A$$

$$V_{out} = -(3k \parallel 4k) 742.6\mu A = -1.273$$

6) Determine the 2-port model for three cascaded CE amplifiers

R 900 + 100*mo + day	Rin	Ain	Rout	Ao
<b>1414</b>	<b>2000</b>	<b>0</b>	<b>1414</b>	<b>-9266</b>

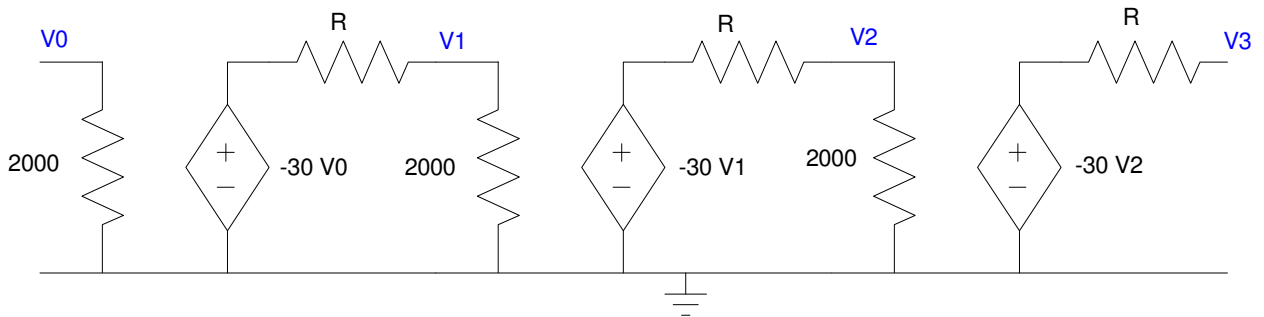

Aout: Apply 1V to Vin

$$V_0 = 1V$$

$$V_1 = \left( \frac{2000}{2000+1414} \right) (-30)(V_0) = -17.57V$$

$$V_2 = \left( \frac{2000}{2000+1414} \right) (-30)(V_1) = +308.9V$$

$$V_3 = (-30)V_2 = -9266V$$

