

ECE 321 - Quiz #2 - Name _____

Sensors & Calibration

1) A thermistor has a temperature-resistance relationship of (Digikey part number P1010TR-ND) where T is the temperature in degrees C.

$$R_t = 3000 \cdot \exp\left(\frac{4000}{T+273} - \frac{4000}{298}\right) \Omega$$

Assume

$$R = 900 + 100 \cdot (\text{your birth month}) + (\text{your birth day})$$

If X = 2.20V, determine the resistance, R, and the temperature, T

R 1100 + 100*mo + day	X volts	R _t Ohms	T degrees C
1414 ohms	2.20V	398.821 ohms	77.725 C

$$2.2V = \left(\frac{R_t}{1414 + R_t}\right) 10V$$

$$R_t = \left(\frac{2.2V}{10V - 2.2V}\right) 1414\Omega = 398.821\Omega$$

$$398.821\Omega = 3000 \cdot \exp\left(\frac{4000}{T+273} - \frac{4000}{298}\right) \Omega$$

$$T = 77.725^\circ C$$

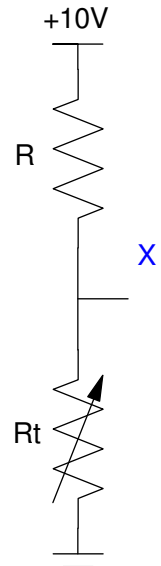

2) A thermistor has a temperature-resistance relationship of (Digikey part number P 1010TR-ND) where T is the temperature in degrees C.

$$R_t = 3000 \cdot \exp\left(\frac{4000}{T+273} - \frac{4000}{298}\right) \Omega$$

Design a circuit which outputs

- -10V at -10C and
- +10V at +40C

Assume

$$R = 900 + 100 \cdot (\text{your birth month}) + (\text{your birth day})$$

note: A linearizing circuit isn't required.

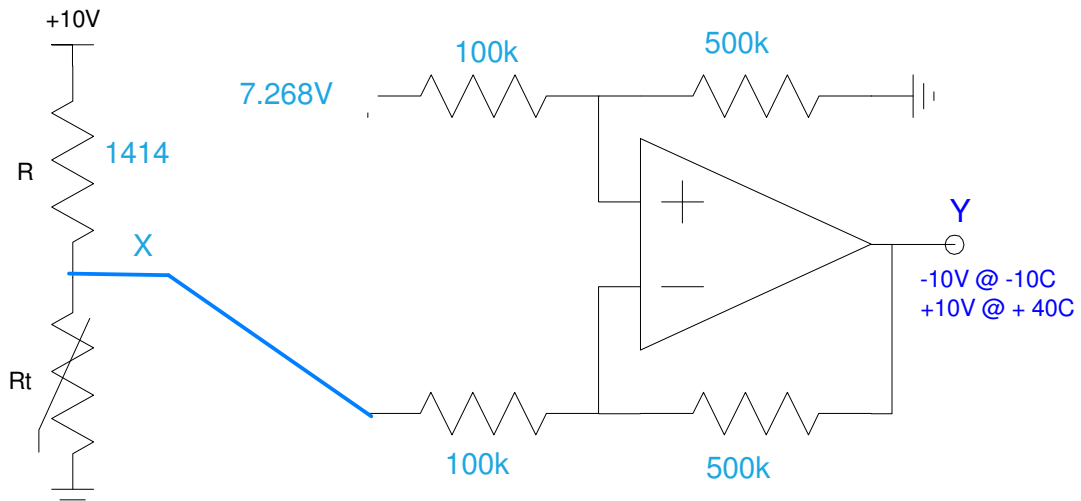

At T = -10C

- R = 17,902.117 Ohms
- X = 9.268V
- Y = -10V

At T = +40C

- R = 1576.179 Oms
- X = 5.272V
- Y = +10V

As X goes down, Y goes up. Connect to the minus input

The gain is

$$gain = \left(\frac{10V - (-10V)}{9.268V - 5.272V}\right) = 5.005$$

At -10C, the output is -10V

$$Y = -10V = 5.005(A - 9.268V)$$

$$A = 7.268V$$

3) Strain Sensor: A beam of length d deflects by 15mm. Determine the

- The radius of curvature,
- Strain on the inside of the beam, and
- Strain on the outside of the beam.

Assume

- The length of the beam is d ($900 + 100 \cdot \text{mo} + \text{day}$) mm
- The thickness of the beam is 3mm

length, d (mm) $900 + 100 \cdot \text{m} + \text{day}$	Radius of Curvature (mm)	Strain inside edge	Strain outside edge
1414 mm	16,669 mm	- 0.000 0899	+ 0.000 0899

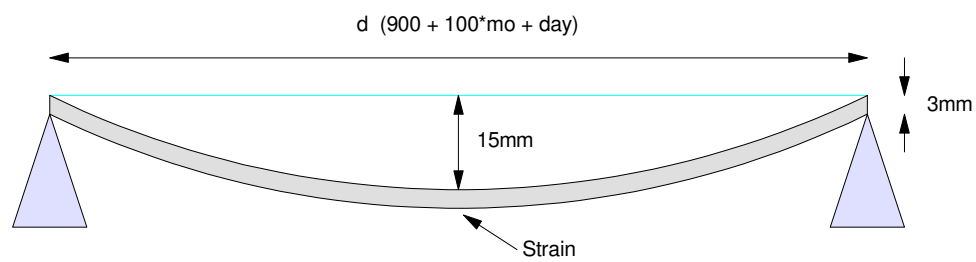

$$R^2 = 707^2 + (R - 15)^2$$

Solving

$$R = 16,669.133\text{mm}$$

The strain is then

$$\epsilon = \left(\frac{1.5\text{mm}}{16,669.133\text{mm}} \right) = 8.999 \cdot 10^{-5}$$

4) Strain Sensor. Assume a strain sensor has a resistance - strain relationship of

$$R_t = 1000 \cdot (1 + 2.14\epsilon) \quad \Omega$$

where

- $R = 900 + 100 \cdot (\text{your birth month}) + (\text{your birth date})$

Design a circuit which outputs

- 0V at $\epsilon = 0$ (zero strain) and
- +10V at $\epsilon = 0.01$ (strain = 0.01)

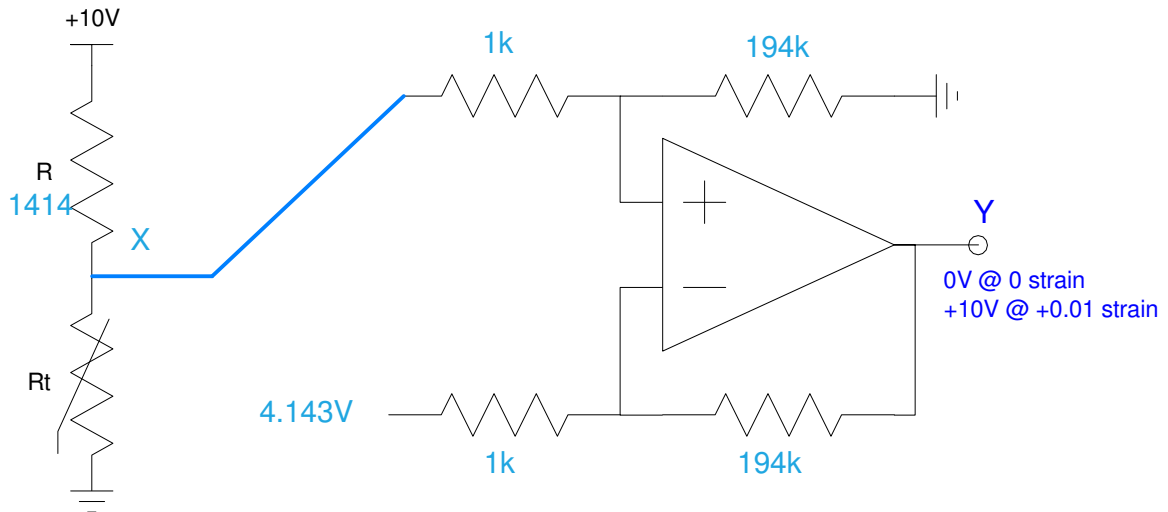

0 Strain

- $R_t = 1000$ Ohms
- $X = 4.143$ Volts
- $Y = 0V$

+0.01 Strain

- $R_t = 1021.4$ Ohms
- $X = 4.194$ Volts
- $Y = +10$ Volts

As X increases, Y increases

- Connect to the plus input

$Y = 0$ when $X = 4.143V$

- Make the offset 4.143 Volts

The gain needed is

$$gain = \left(\frac{10V}{4.194V - 4.143V} \right) = 194.28$$

5) A thermistor has a temperature-resistance relationship of

$$R_t = 3000 \cdot \exp\left(\frac{4000}{T+273} - \frac{4000}{298}\right) \Omega$$

where T is the temperature in degrees C. Assume the thermistor is used with a voltage divider so that

$$V = \left(\frac{R_t}{R_t+R}\right) 10V$$

where

$$R = 900 + 100 \cdot (\text{your birth month}) + (\text{your birth day})$$

Determine the least squares curve fit for temperature as

$$T = aV + b$$

over the range of -10C to +40C.

```
>> T = [-10:0.01:40]';
>> Rt = 3000 * exp( 4000 ./ (T + 273) - 4000/298);
>> X = Rt ./ (Rt + 1414) * 10;
>> B = [X, X.^0];
>> A = inv(B'*B)*B'*T
```

A =

```
-12.0515
106.1119
```

$$T \approx -12.05V + 106.11$$

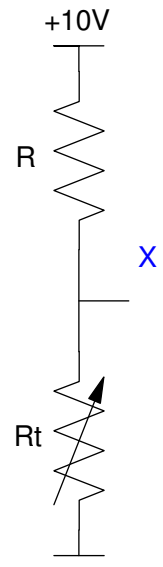

6) A thermistor has a temperature-resistance relationship of

$$R_t = 3000 \cdot \exp\left(\frac{4000}{T+273} - \frac{4000}{298}\right) \Omega$$

where T is the temperature in degrees C. Assume the thermistor is used with a voltage divider so that

$$V = \left(\frac{R_t}{R_t+R}\right) 10V$$

where

$$R = 900 + 100 \cdot (\text{your birth month}) + (\text{your birth day})$$

Determine the least squares curve fit for temperature as

$$T = aV^2 + bV + c$$

over the range of -10C to +40C.

```
>> T = [-10:0.01:40]';  
>> Rt = 3000 * exp( 4000 ./ (T + 273) - 4000/298);  
>> X = Rt ./ (Rt + 1414) * 10;  
>> B = [X.^2, X, X.^0];  
>> A = inv(B'*B)*B'*T
```

A =

```
-1.2813  
 6.8738  
38.0809
```

$$T \approx -1.28V^2 + 6.87V + 38.08$$

