

ECE 321 - Homework #4

Butterworth & Chebychev filters, Analog Computers. Due Monday, April 26th

Please make the subject "ECE 321 HW#4" if submitting homework electronically to Jacob_Glower@yahoo.com (or on blackboard)

Analog Computers

1) Design an analog computer to implement

$$Y = \left(\frac{10s+15}{s^3+7s^2+2s+20} \right) X$$

Butterworth and Chebychev Filters

Design a filter for your cell-phone to speaker circuit. Some suggestions are...

- Subwoofer Crossover. Pass frequencies below 250Hz. Reject frequencies above 500Hz.
- Cow-Bell Filter: Pass frequencies between 590 and 630Hz. Reject frequencies below 500Hz or above 700Hz.
- Middle-C Filter: Pass frequencies between 220Hz and 440Hz. Reject frequencies below 150Hz and above 650Hz.
- Other...

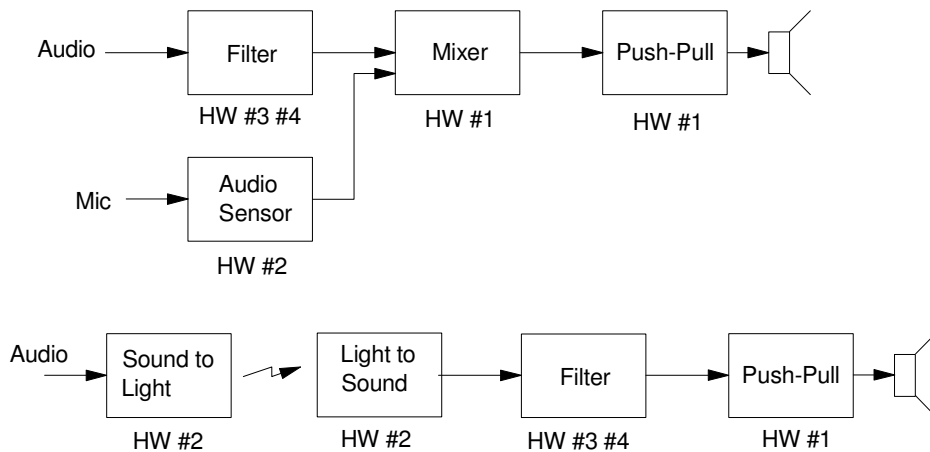

2) Requirements. Specify

- The frequencies that should be passed ($0.9 < \text{gain} < 1.1$),
- The frequencies that should be rejected ($\text{gain} < 0.2$)

3) Filter design:

- Give the transfer function for a filter which meets your requirements.
- Plot the gain vs. frequency of your filter.

4) Simulation: Simulate your filter in CircuitLab to verify that it meets your requirements

- $0.9 < \text{gain} < 1.1$ in the pass-band region, and
- $\text{gain} < 0.2$ in the band-reject region

5) Hardware: Build your filter and verify it meets your requirements.

- $0.9 < \text{gain} < 1.1$ in the pass-band region, and
- $\text{gain} < 0.2$ in the band-reject region

6) Demo: Demonstrate your pre-amp - filter - power amp circuit.