

ECE 321 - Homework #3

Calibration, Filter Circuits, and Frequency Response. Due Monday, April 19th

Please make the subject "ECE 321 HW#3" if submitting homework electronically to Jacob_Glower@yahoo.com (or on blackboard)

Calibration

Problem 1 & 2) Assume you are using a thermistor where the temperature - resistance relationship is

$$R = 1000 \exp\left(\frac{3905}{T+273} - \frac{3905}{298}\right) \Omega$$

where T is the temperature in degrees C. Assume this is used along with a voltage divider (5V source, 2k resistor:

$$V = \left(\frac{R}{R+2000}\right) \cdot 5V$$

1) Determine a calibration function of the form

$$T \approx aV + b$$

to estimate temperature over the range of (+10C .. +30C). What is the maximum error in this calibration function?

In matlab

```
>> T = [10:0.1:30]';
>> R = 1000 * exp(3905 ./ (T+273) - 3905/298);
>> V = R ./ (R+2000) * 5;

>> B = [V, V.^0];
>> A = inv(B'*B)*B'*T

-18.6498
 56.1622

>> plot(V,T,'b',V,B*A,'r')
>> xlabel('Voltage');
>> ylabel('Degrees C');

>> mean(T - B*A)
-3.4679e-014

>> std(T - B*A)
 0.2555

>> max(abs(T - B*A))
 0.6120
```

Curve Fit:

$$T \approx -18.6498V + 56.1622$$

maximum error:

0.6120 degrees

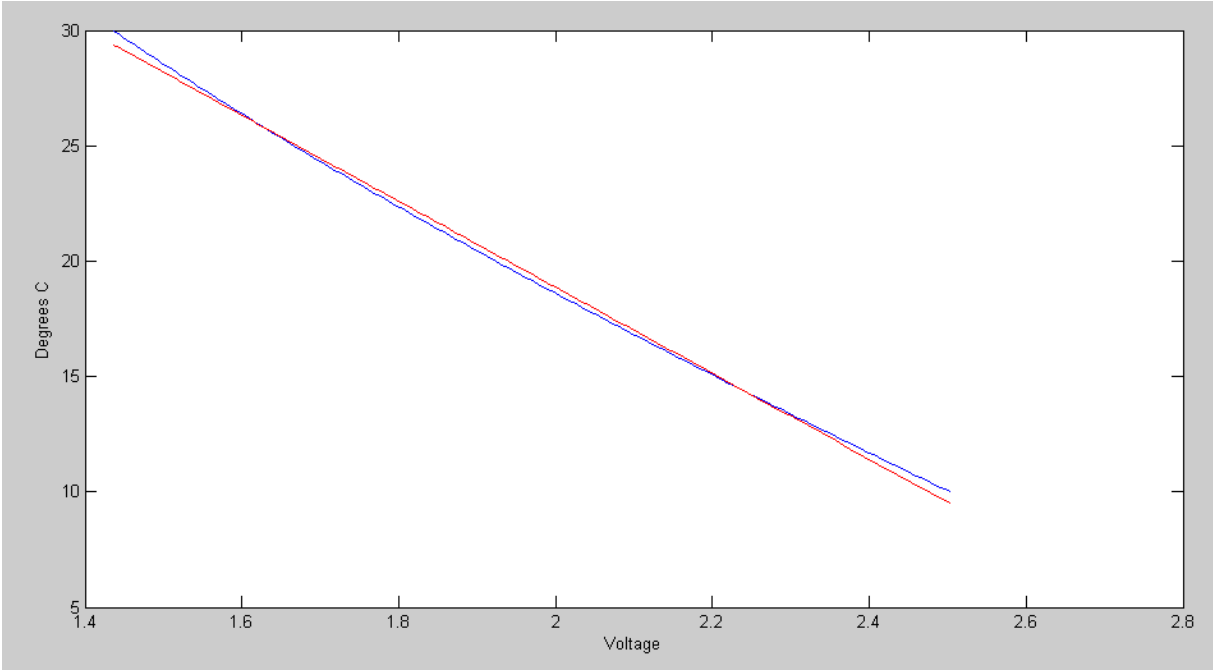

Linear Curve Fit: Actual Temperature (blue) and Estimated (red)

2) Determine a calibration function of the form

$$T \approx aV^3 + bV^2 + cV + d$$

to estimate temperature over the range of (+10C .. +30C). What is the maximum error in this calibration function?

```
>> B = [V.^3, V.^2, V, V.^0];  
>> A = inv(B'*B)*B'*T
```

```
a   -1.5830  
b   12.2536  
c  -48.1492  
d   78.5430
```

```
>> plot(V,T,'b',V,B*A,'r')  
>> mean(T - B*A)  
    2.9552e-010
```

```
>> std(T - B*A)  
    0.0034
```

```
>> max(abs(T - B*A))  
    0.0102
```

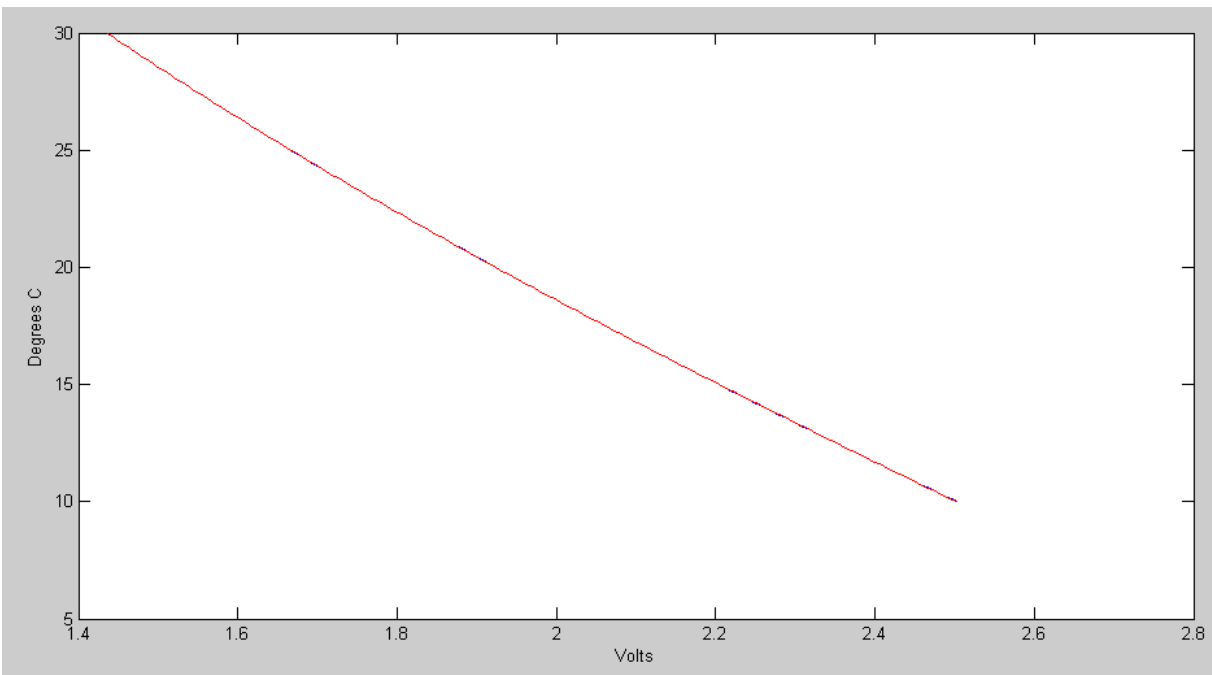

Cubic Curve Fit: Actual Temperature (blue) and Estimated (red)

Filters

3) Assume X and Y are related by the following transfer function:

$$Y = \left(\frac{40}{(s+2)(s+7)} \right) X$$

a) What is the differential equation relating x and y?

Cross multiply

$$(s^2 + 9s + 14)Y = 40X$$

'sY' means 'the derivative of Y'

$$y'' + 9y' + 14y = 40x$$

b) Determine y(t) assuming

$$x(t) = 4 + 5 \cos(7t) + 6 \sin(7t)$$

Use superposition

$$x(t) = 4$$

$$s = 0$$

$$X = 4$$

$$Y = \left(\frac{40}{(s+2)(s+7)} \right)_{s=0} \cdot (4)$$

$$Y = 11.428$$

meaning

$$y(t) = 11.428$$

$$x(t) = 5 \cos(7t) + 6 \sin(7t)$$

$$s = j7$$

$$X = 5 - j6$$

$$Y = \left(\frac{40}{(s+2)(s+7)} \right)_{s=j7} \cdot (5 - j6)$$

$$Y = 4.2588 - j0.8086$$

meaning

$$y(t) = 4.2588 \cos(7t) + 0.8086 \sin(7t)$$

The total answer is DC + AC

$$y(t) = 11.4288 + 4.2588 \cos(7t) + 0.8086 \sin(7t)$$

Filter Design using *fminsearch()*

4) Design a filter of the form

$$Y = \left(\frac{ace}{(s+a)(s^2+bs+c)(s^2+ds+e)} \right) X$$

to give a gain vs. frequency as close to $G_d(s)$ as possible over the range of (0, 10) rad/sec.

$$G_d(j\omega) = \begin{cases} 1 & 0 < \omega < 2 \\ 0.5 & 2 < \omega < 4 \\ 0 & \omega > 4 \end{cases}$$

Plot your filter's actual frequency response vs. its ideal response (given by G_d).

In Matlab:

```
>> [Z,e] = fminsearch('costF',[1,2,3,4,5])  
  
Z = 1.0704 1.2733 3.0809 0.5159 13.3705  
e = 3.9449  
  
>> [Z,e] = fminsearch('costF',Z)  
Z = 1.0704 1.2733 3.0808 0.5159 13.3705  
e = 3.9449
```

$$G(s) = \left(\frac{44.0932}{(s+1.0704)(s^2+1.2733s+3.0809)(s^2+0.5159s+13.3704)} \right)$$

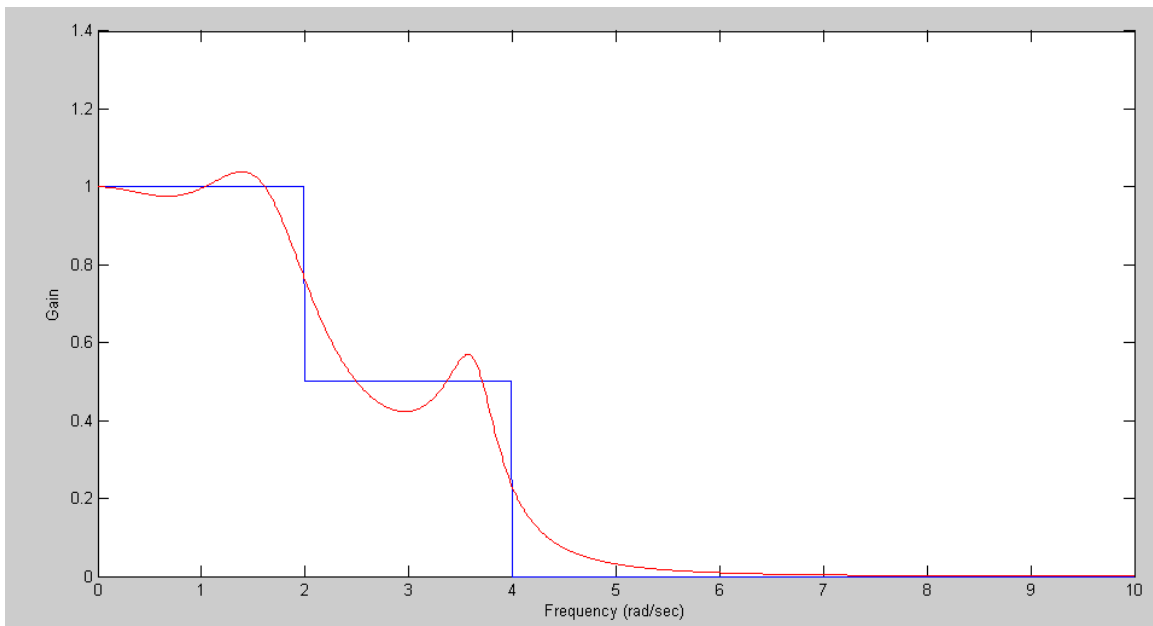

Filter's ideal response (blue) and actual response (red)

5) Design circuit to implement the filter you designed in problem #4

Build this in three stages

$$G(s) = \left(\frac{a}{s+1.0704} \right) \left(\frac{b}{(s^2+1.2733s+3.0809)} \right) \left(\frac{c}{(s^2+0.5159s+13.3704)} \right)$$

$$\text{Stage 2: } G_2 = \left(\frac{b}{(s^2+1.2733s+3.0809)} \right) = \left(\frac{b}{s+1.7552 \angle \pm 68.73^\circ} \right)$$

$$\frac{1}{RC} = 1.7552$$

$$C = 1\mu\text{F}$$

$$R = 570\text{k}$$

$$3 - k = 2 \cos(68.73^\circ)$$

$$k = 2.2745$$

$$R1 = 100\text{k}$$

$$R2 = 127.45\text{k}$$

$$\text{Stage 3: } G_3 = \left(\frac{c}{s^2+0.5159s+13.3704} \right) = \left(\frac{c}{s+3.6566 \angle \pm 85.95^\circ} \right)$$

$$\frac{1}{RC} = 3.6566$$

$$C = 1\mu\text{F}$$

$$R = 273\text{k}$$

$$3 - k = 2 \cos(85.95^\circ)$$

$$k = 2.8587$$

$$R1 = 100\text{k}$$

$$R2 = 185.87\text{k}$$

$$\text{Stage 1: } G_1 = \left(\frac{a}{s+1.0704} \right)$$

$$\frac{1}{RC} = 1.0704$$

$$R = 93.4\text{k} (\ll R(\text{Stage 2}))$$

$$C = 10\mu\text{F}$$

The resulting DC gain is $k*k = (2.2745)(2.8587) = 6.5021$

call the output 6.5021Y

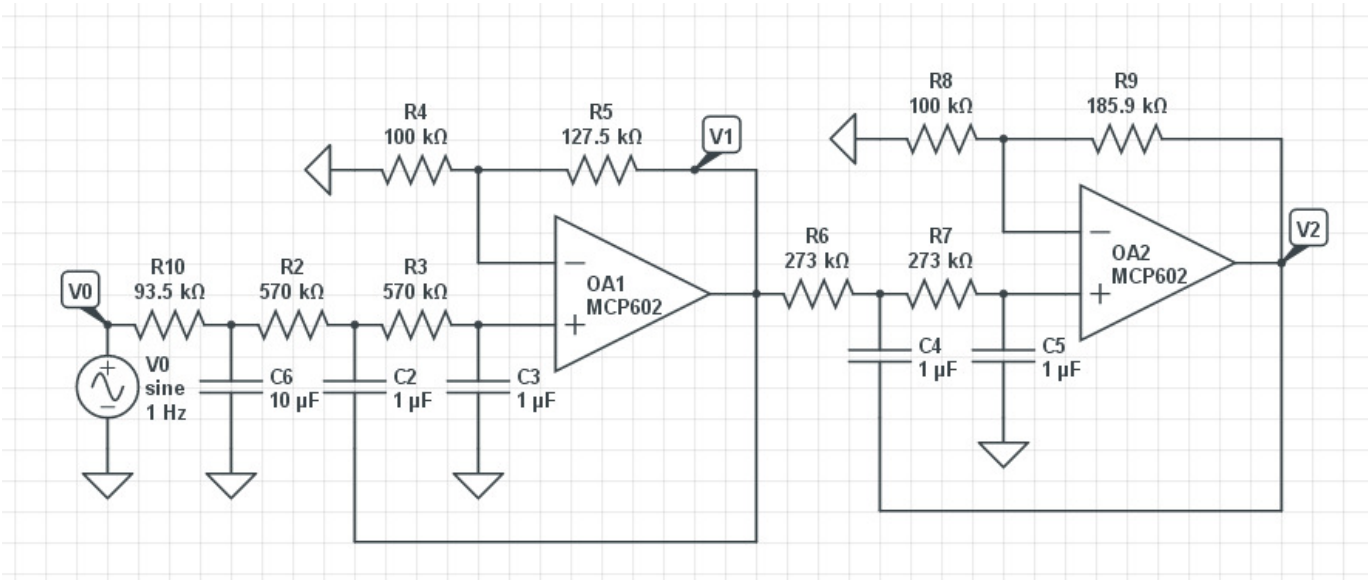

6) Check your filter using CircuitLab

