

ECE 321 - Homework #1

Op Amp Amplifiers, Push-Pull Amplifiers. Due Monday, November 8th

Please make the subject "ECE 321 HW#1" if submitting homework electronically to Jacob_Glower@yahoo.com (or on blackboard)

For all problems, assume you are using

- MCP602 Op Amps (max current = 50mA)
- 2SC6144 transistors ($\beta = 200$, 10A max, $V_{be1} = 0.7V$)

Amplifier:

Design a circuit to implement

1a) $Y = +3X$

1b) $Y = -3X$

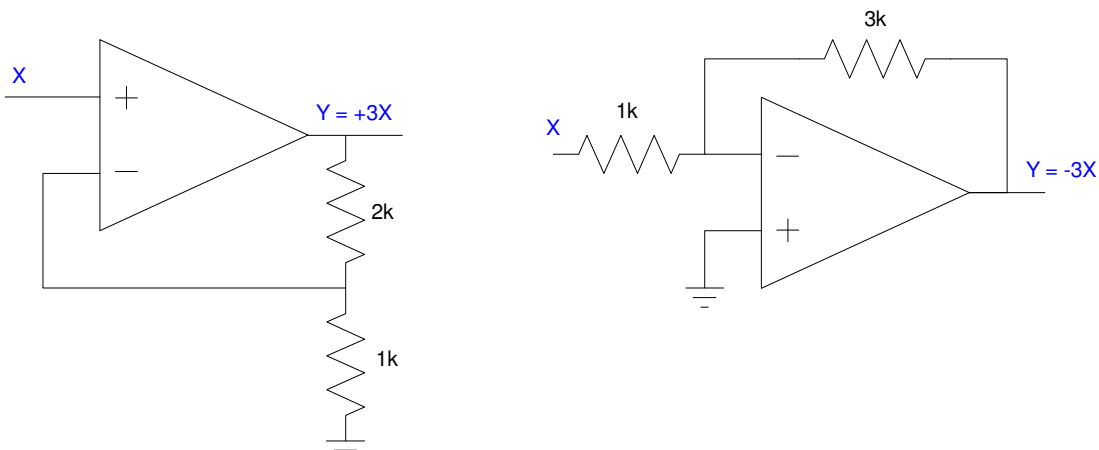

1c) $Y = 12 - 4X$

Rewrite as

$$Y = 4(3 - X)$$

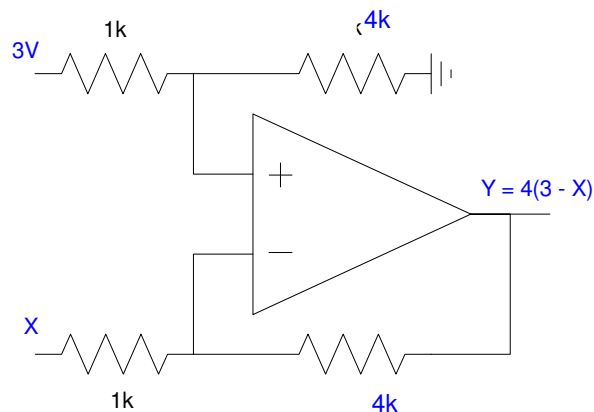

Mixer

2) Design a circuit to mix three signals together:

- $Y = 6A + 1B + 3C$

Option 1: Rewrite as

$$Y = 10 \left(\frac{6A+B+3C}{10} \right)$$

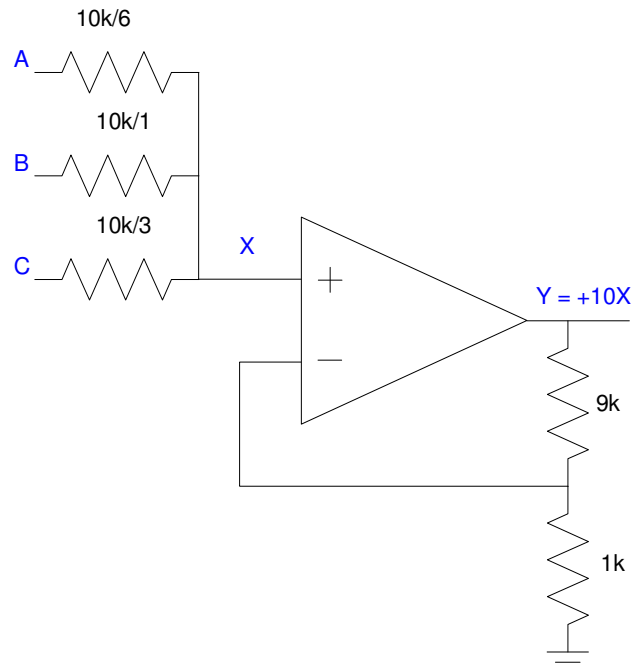

Option 2: Use inverting summing amplifiers

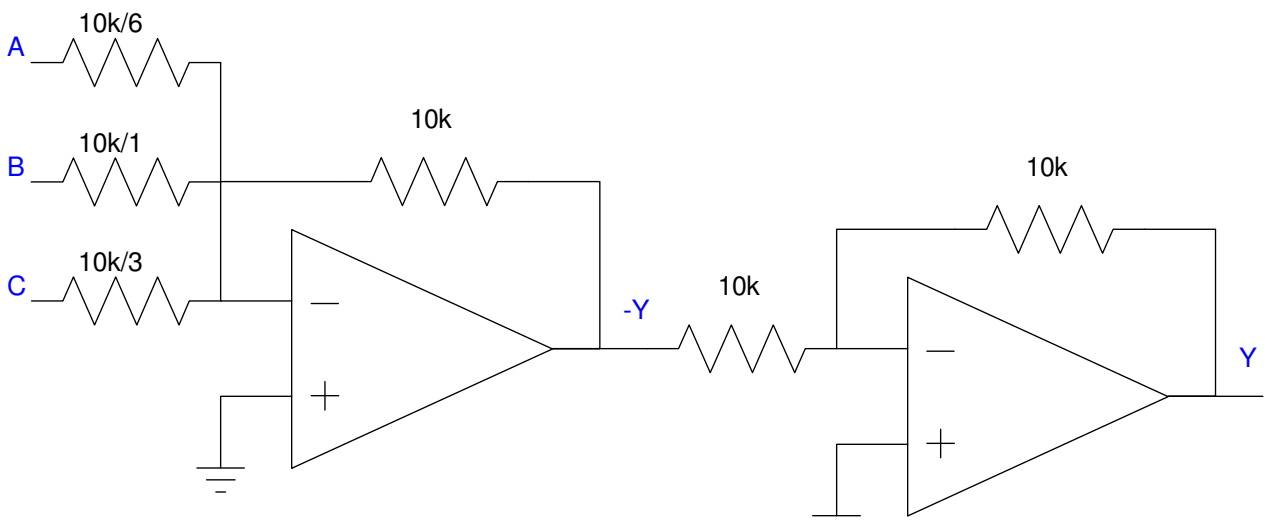

Push-Pull Amplifier

3) Design a circuit so that $Y = X$

- $X = -5V$ to $+5V$, $10mA$ max
- $Y = -5V$ to $+5V$, $200mA$ ($25\ \Omega$ speaker (net))

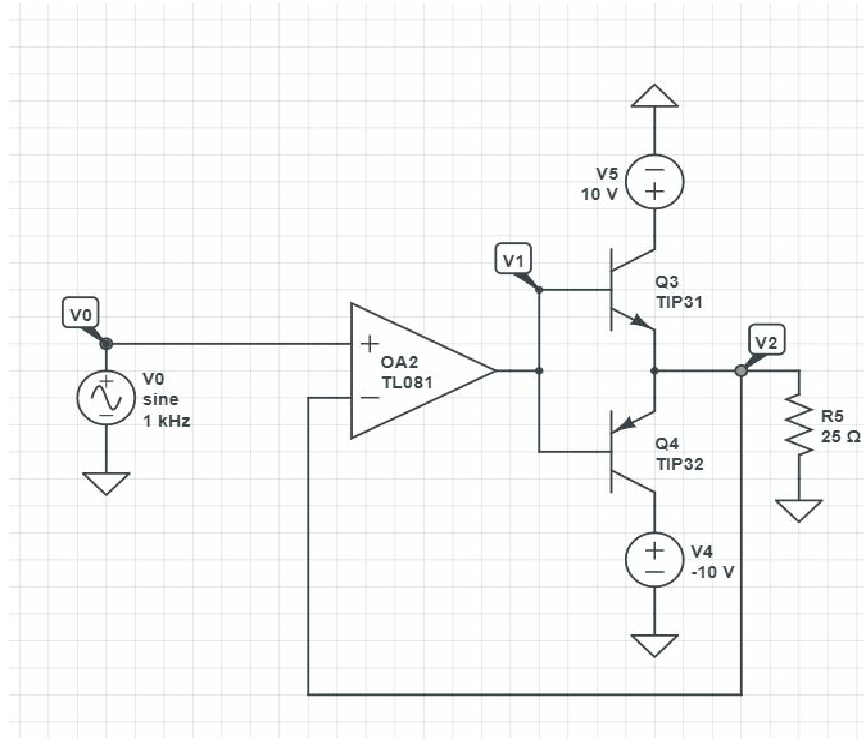

4) Simulate in CircuitLab

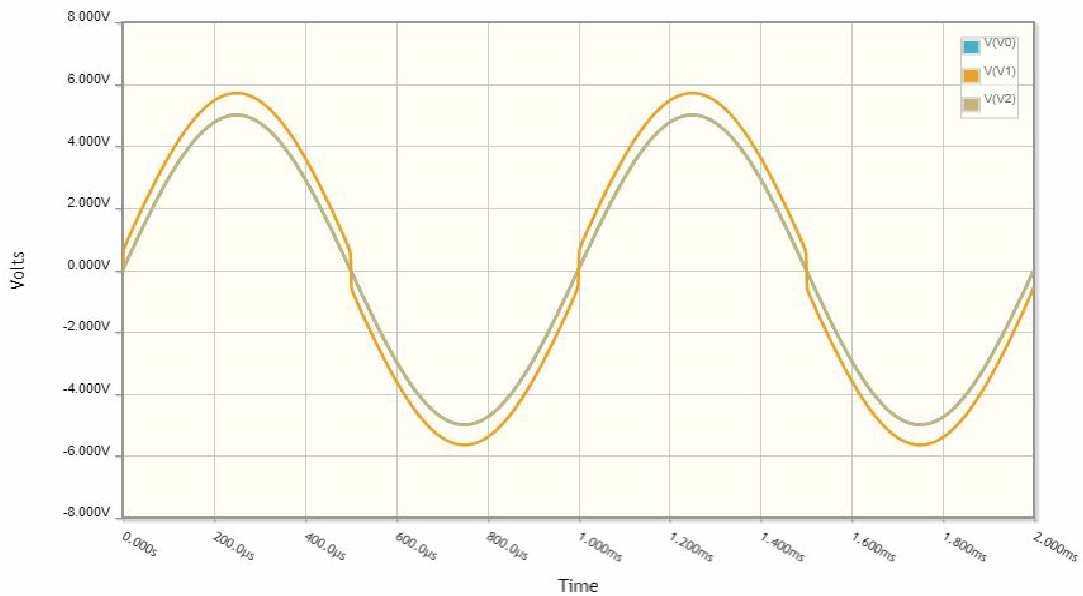

Lab (Hardware)

The following circuit

- Creates a 2.5V power supply from a single +5V supply (V0). This 2.5V supply then acts like circuit ground
- Amplifies the output of a cell phone (or computer or 555 timer) (V2), and
- Drives an 8 Ohm speaker (V3)

5) Calculate the voltages and currents when

V1 = 2.0V

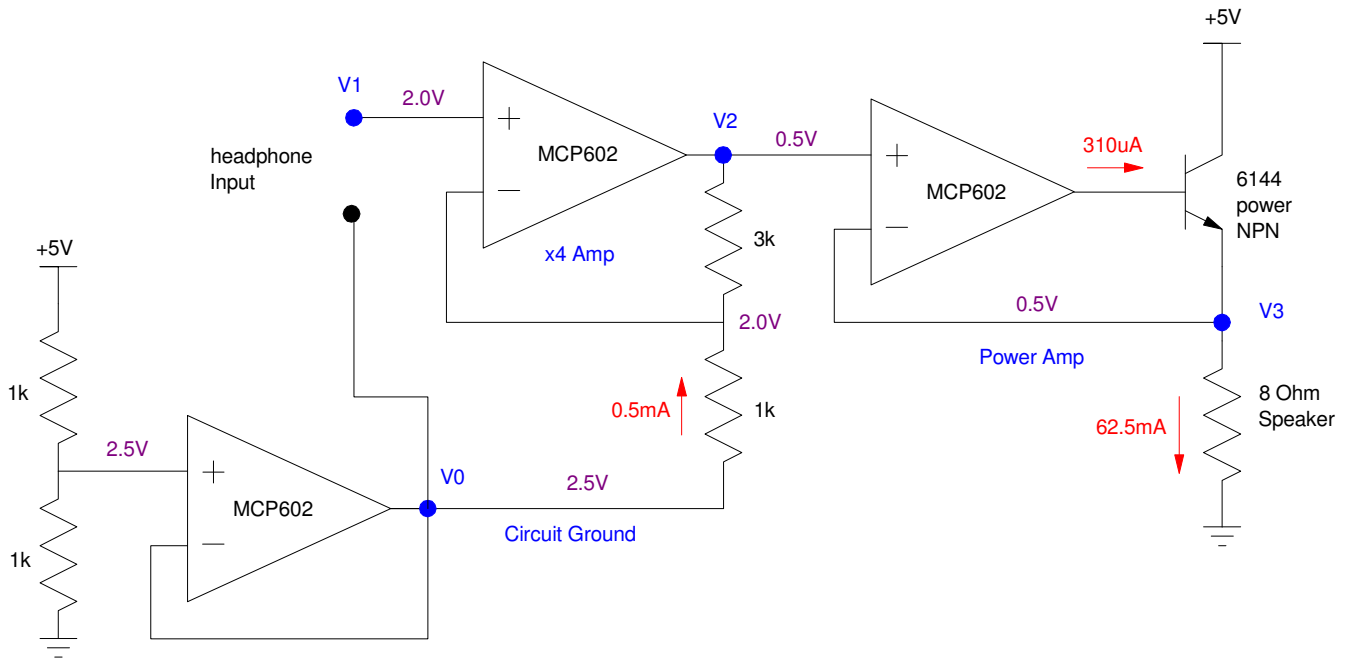

V1 = 2.5V

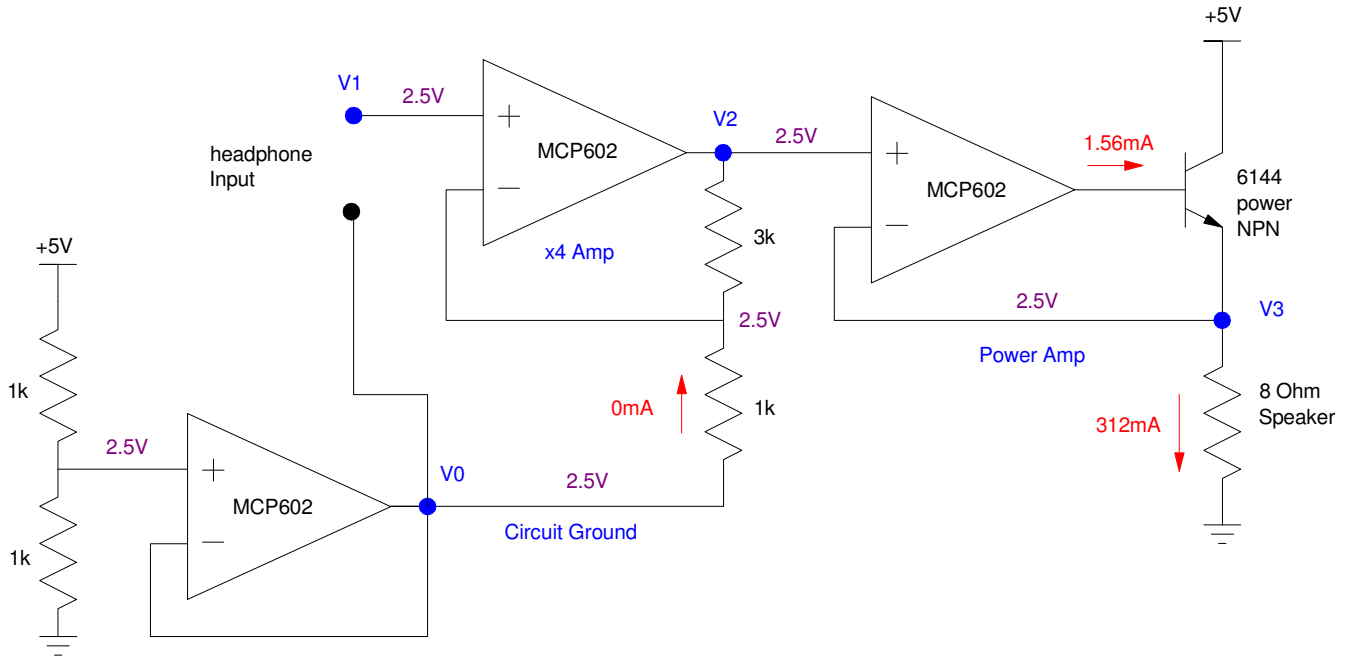

V1 = 3.0V

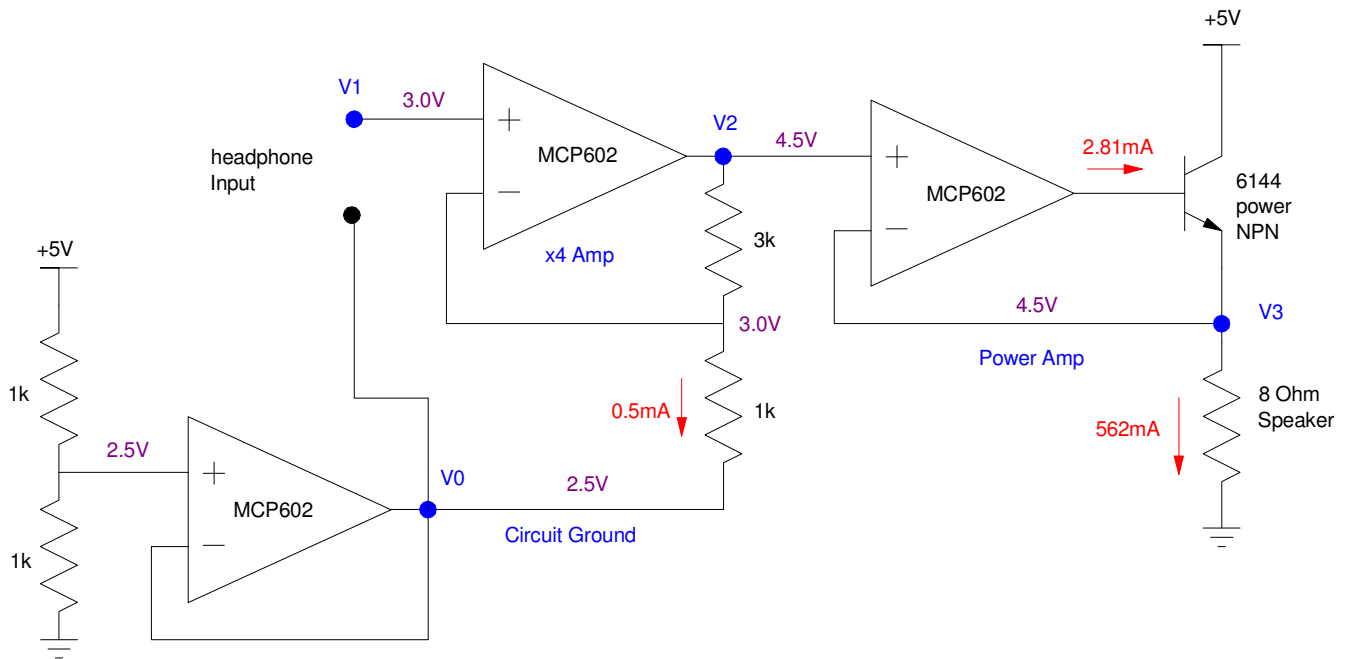

6) Simulate this circuit in CircuitLab with

- $V_1 = 1V_{pp}$, 1kHz sine wave

Note:

- $V_1 = 4 \cdot V_0$, centered at 2.5V (circuit ground)
- $V_2 = V_1$

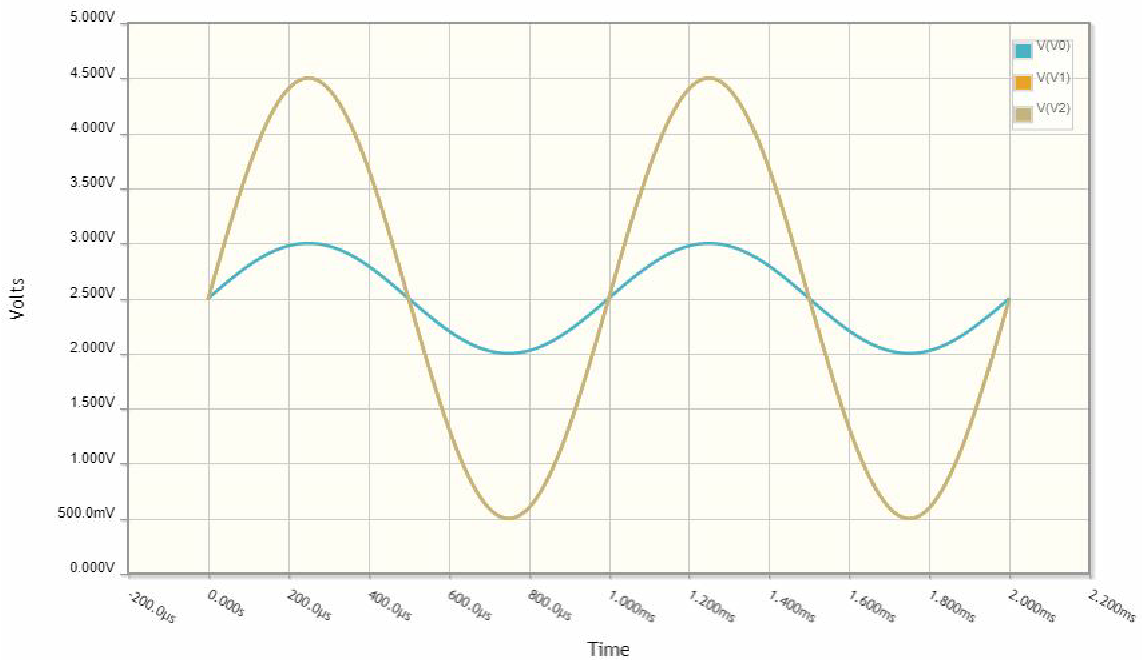
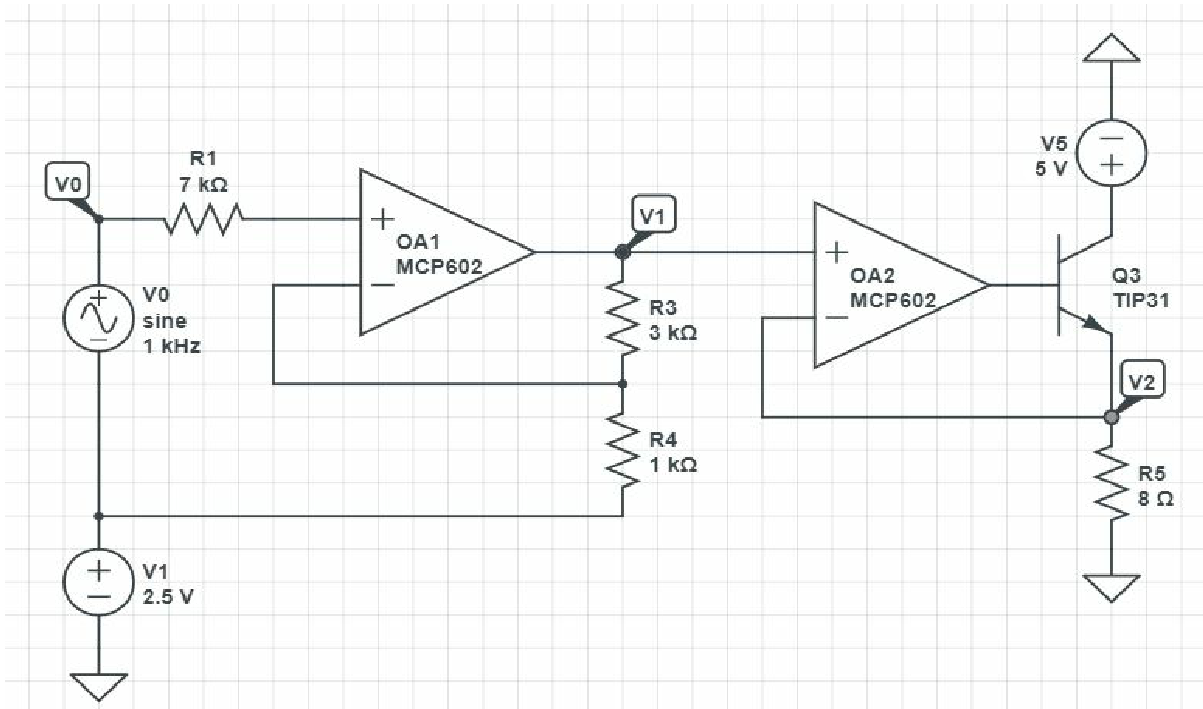

7) Build this circuit in hardware. With a sine wave input, (1kHz) verify that that

- $V_2 = 4 \cdot V_1$ (relative to circuit ground)
- $V_3 = V_2$ (relative to circuit ground)

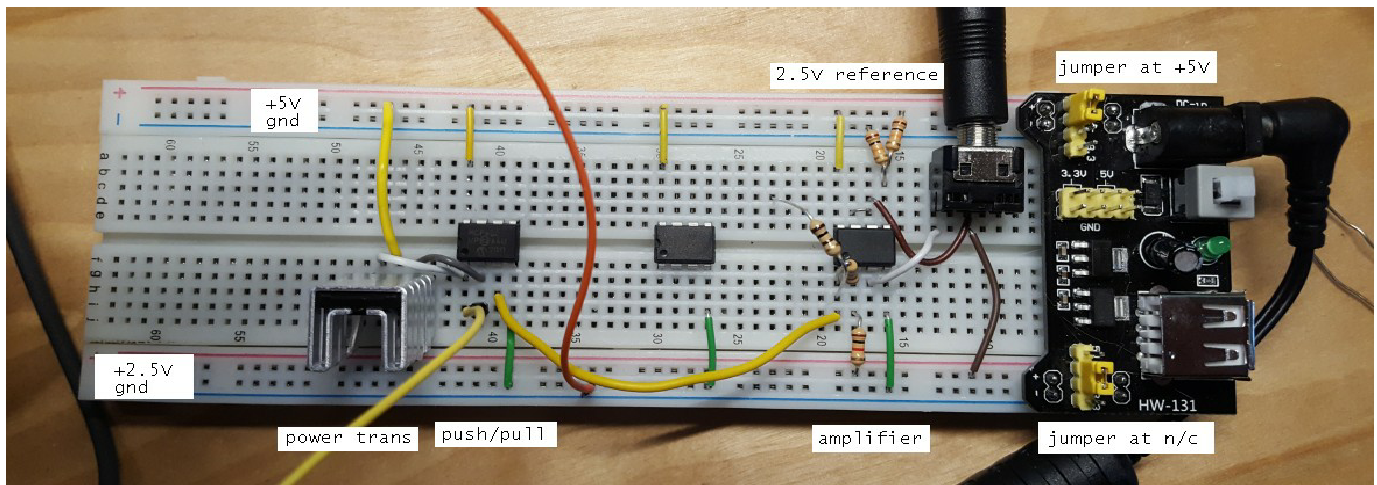

Using OnLineToneGenerator.com, a 440Hz sine wave was applied to the input

- $V_1 = 44\text{mVrms}$
- $V_2 = 131\text{Vrms sine wave}$
- $V_3 = 131\text{Vrms sine wave}$

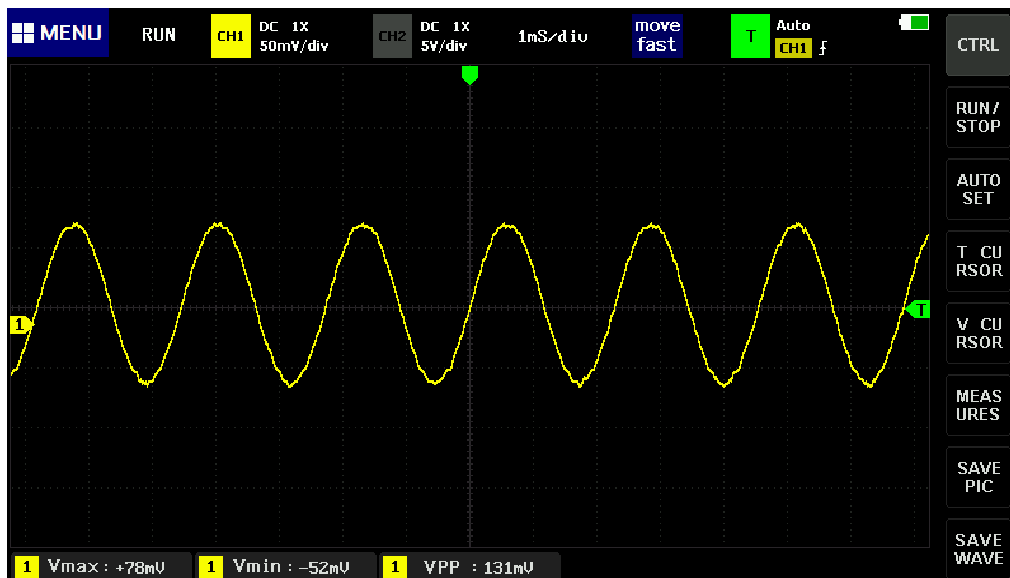

8) Demo

- Replace V1 with an audio signal and verify the song plays on the speaker

Playing "Hot and Cold" by Elmo and Ms. Perry

